

M403 4 AXIS MACHINING CENTER

M403 4 AXIS CNC MACHINING CENTER 3,2 METERS WITH 12 POSITIONS TOOL CHANGER

The CNC machining center features 4 controlled axes and is designed for operations on bars or pieces made of aluminum, PVC, light alloys, and steel with a thickness of up to 2mm. It has a working area equipped with a single pneumatic zero stop that allows the processing of profiles up to 3.2 meters in length. This length can be doubled with the optional installation of a second zero stop. The electric spindle, with its 4th rotating axis, can machine the profile at any angle between 0° and 180°. The center includes an 8-position tool magazine located in the middle of the bed frame, allowing quick access to tools from anywhere in the machine. The profile is held by 4 clamps with a compact design to maximize workability, even on small pieces.



TECHNICAL DETAILS

- It consists of a base and a vertical column that slides on the rear. Both are made of electro-welded steel and are then subjected to careful processing under very high precision machining centers.
- The movement of the axes takes place on linear guides of high strength and precision, the linear bearing slides are automatically lubricated by a pump.
- The axes are controlled by Brushless digital servomotors to allow a quick adjustment and give a high response speed during the work phase
- Helical rack and pinion for the X axis (longitudinal)
- Helical rack and pinion for the Y axis (transverse) and 25x10 for the Z axis (vertical). The Z axis motor is equipped with an electromagnetic brake in the event of a power failure it stops.

ELECTROSPINDLE

- Equipped with 5 kW S1 – 6.6 kW S6 spindle with rotation speed up to 21,000 rpm. HSK63F tool attachment for very high holding of the tool itself, it is equipped with sensors for tool presence and coupling/release.
- The rotation speed of the electrospindle is managed by the CNC control through a vector inverter, which allows you to manage a high copy even at a low rpm.

TOOL LUBRICATION

The tool is lubricated with only oil using the micro-drop system (minimal lubrication).

CLAMPS

The clamp unit is large, robust, and compact, designed to ensure proper clamping of large or small profiles. A simple manual adjustment allows for quick repositioning of the moveable stop to accommodate different profile types, facilitating shape changes.

In the basic version, the clamps are positioned along the X-axis according to the CNC's instructions using a small bracket that automatically attaches to them.

The positions are always controlled by CAD-CAM, reducing movement time, ensuring precise positioning, and eliminating manual errors.



TOOL MAGAZINE

It is in a fixed position behind the X-axis base with 12 positions.

A pneumatic controlled enclosure protects the tools from chips.

11 places are for traditional tools and 1 is dedicated to a slitting blade diam. 200 mm.

WORKING AREA

The work area consists of 4 compact clamps with quick adjusting pneumatic cylinders to lock the profiles.

The work area has 2 retractable stops (left and right) activated by pneumatic cylinders that turn up or down the stop of the zero piece. The combination of left and right stops allow the use of pieces longer than the machine until twice the machine length.

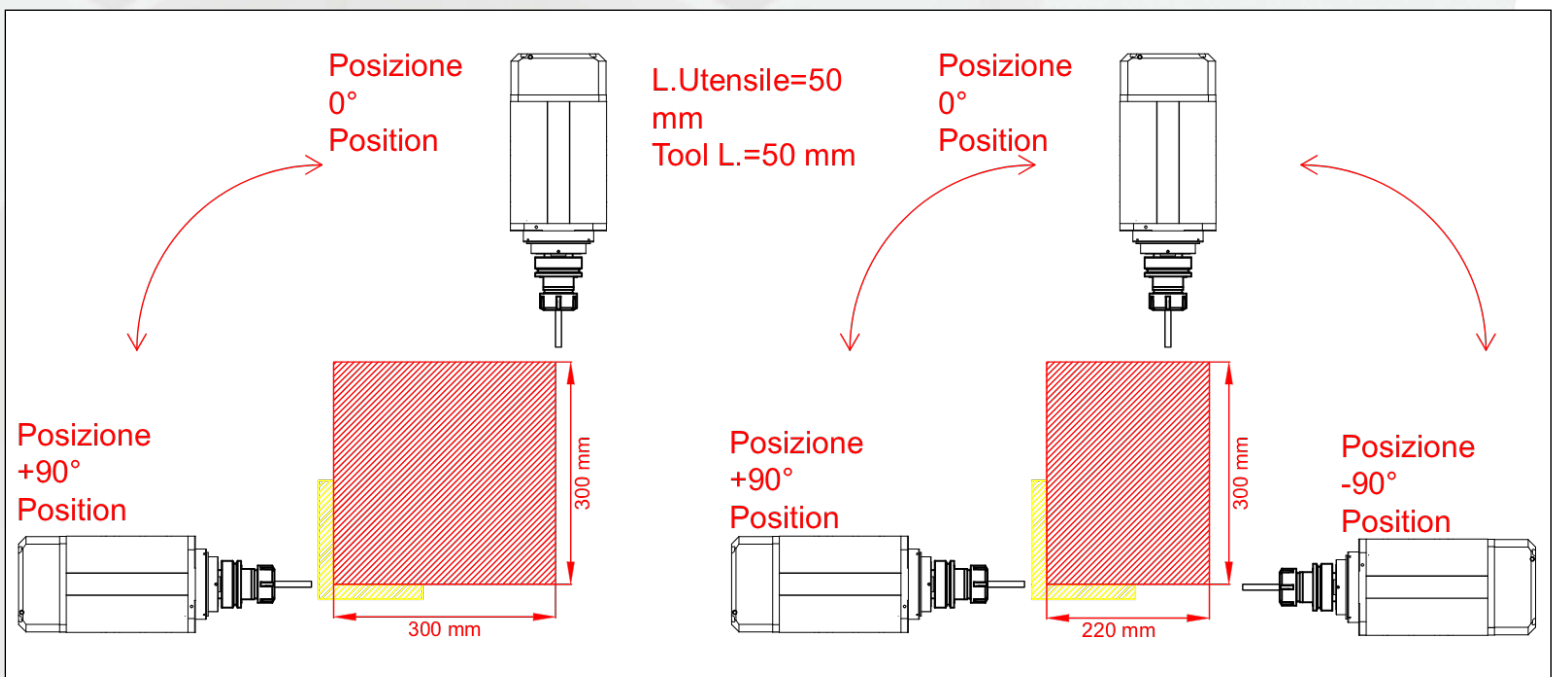

M403 4 AXIS MACHINING CENTER

AXIS STROKES

X Axis - Longitudinal Stroke	mm	3400
Y Axis - Transversal Stroke	mm	1170
Z Axis - Vertical Stroke	mm	585
A Axis - Spindle rotation		90° / -90°
Number of clamps	Pc.	4

WORKING CAPACITY

X Axis	Longitudinal working capacity	Without end milling	mm	3400
		With end milling in mm	mm	3200
Y Axis	Transversal working capacity With spindle at (tool height 50 mm)	0°	mm	300
		+90°	mm	300
		-90°	mm	200
Z Axis	Vertical working capacity With spindle (tool height 50 mm)	0°	mm	300
		+90°	mm	300
		-90°	mm	300

AXIS MOVIMENTS

X Axis	Rapid movement	m/min	100
Y Axis	Rapid movement	m/min	85
Z Axis	Rapid movement	m/min	25

ELECTROSPINDLE

Tool holder	HSK63F
Tapping	M8
Power	S1 5 kW - 6,6 S5 kW
Max rotation speed	RPM 21000

TOOL MAGAZINE

Number of tools	No.	12
Maximum tool weight	kg	6
Maximum tool length	mm	160
Maximum tool diameter	mm	20
Maximum slitter blade diameter	mm	200

ELECTRICAL AND PNEUMATIC TECHNICAL DATA

Total requested power	kW	16
Air consumption	NL	800
Pressure	BAR	7

DIMENSIONS

Length	mm	4690
Width	mm	1940
Height	mm	3050
Height for shipping	mm	2400
Weight	kg	2200

M403 4 AXIS MACHINING CENTER



ACCESSORIES ON REQUEST

Tool height measuring device

Workpiece length probe

Motorized clamp movement

Barcode reader

Label printer

Emulsion lubrication kit with recovery tank and water protection guards

8.5 kW liquid-cooled electrospindle

Tool kit for ALU and PVC HSK63F: 2 x 6 mm, 2 x 8 mm, 2 x 10 mm, 2 x 12 mm, 8 tool holders, 1 x Ø120 mm saw blade with tool holder.

